



Waldhornstrasse 12
 D-88662 Überlingen
 Fon: +49 (0) 7551.1234
 Fon: +49 (0) 7551.4444
 Fax: +49 (0) 7551.918888
 www.winkler-technik.com

**Winkler
 Technik**



Expansion Joint Plate-Kit Self-Adhesive

a solution which guarantees professional expansion joints
 in concrete slabs with radiant floor heating

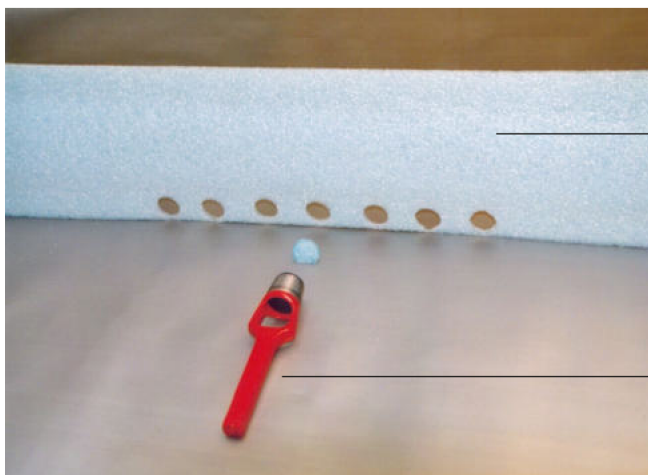

● PE expansion joint plate PED

● punching out tool
 for holes of 24 or
 28 mm (1" or 1 1/8")

● PEX heating pipe with PE sleeve

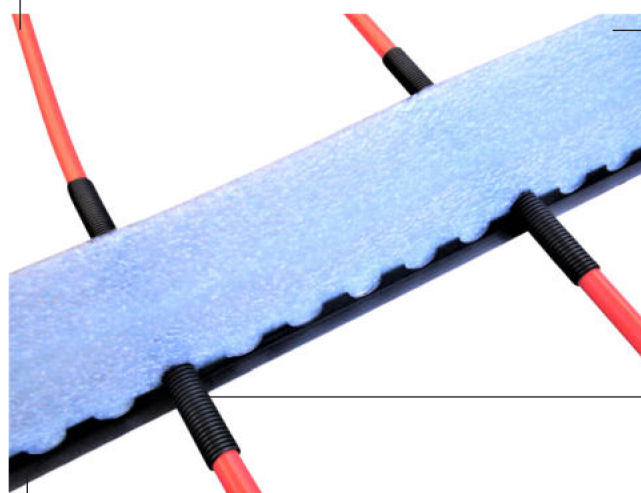

● punch holes in the PE joint plate
 (150 mm = 6" high,
 8 mm = 5/16" thick) where pipe
 runs and then push it into
 the expansion profile

● PE sleeve with slit
 outside diameter 24 mm
 or 28 mm (1" or 1 1/8"),
 30 cm (12") long

● expansion joint profile DFP - 20 mm high (3/4") -
 with double adhesive tape, 2 m (6 1/2 ft) long

Subject to technical changes GT 02. 16/01

Expansion Joint Plate-Kit

Expansion Joint Profile with Double Adhesive Tape DFP

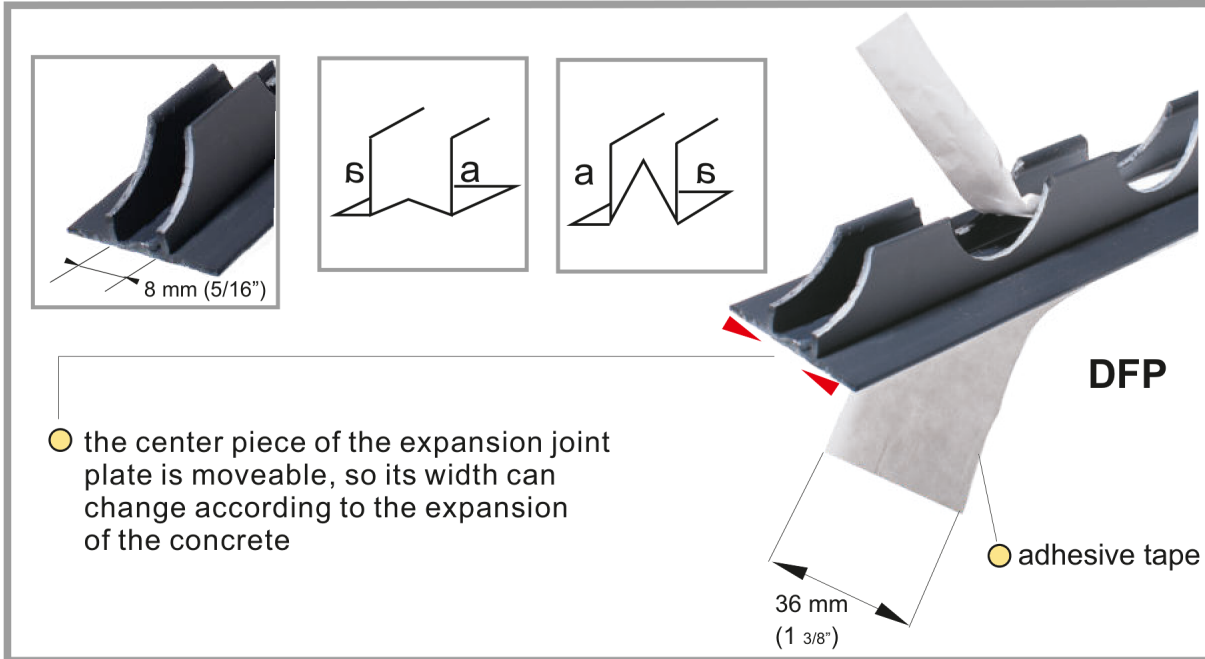

Technical Data

| item No. | packing unit | weight approx. |
|---|---|------------------------|
| expansion joint profile DFP | 50 pcs. of 2 m (6 1/2 ft) each = 100 m (325 ft) packed in carton | 14.0 kg (30.9 lbs.) |
| PE expansion joint plate PED | 8 rolls of 50 m (164 ft) each = 400 m (1312 ft) packed in PE-bags | 9.2 kg (20.2 lbs.) |
| protective PE sleeve SR 24/300 outside diameter 24 mm (1") for tubes up to 18 mm diameter (5/8") 300 mm (12") long | 50 / carton | 1.1 kg (2.4 lbs.) |
| protective PE sleeve SR 28/300 outside diameter 28 mm (1 1/8") for tubes up to 22 mm diameter (3/4") 300 mm (12") long | 50 / carton | 1.4 kg (3.1 lbs.) |
| punching tool LE 24 for punching out holes of 24 mm (1") | 1 pc. loose | 0.3 kg (0.7 lb.) |
| punching tool LE 28 for punching out holes of 28 mm (1 1/8") | 1 pc. loose | 0.4 kg (0.9 lb.) |